

# HOLOVISION

## Manual Type 1.0.0.7 RF "TES2" INTERCOM UNIT

### For Models

100 TES2	303 TES2
102 TES2	500 TES2
106 TES2	501 TES2
200 TES2	504 TES2
202 TES2	505 TES2
300 TES2	506 TES2
303 TES2	511 TES2



### Specifications

#### Communication

TES2 telephone entry system provides a communication link between the front door and every phone in the house. When the button is pressed, the phones in the house will ring with a distinctive ring.

The home owner can then speak to the visitor by answering any of the ringing phones in the House. TES2 is a 2 door system (front door, back door).

#### Access Control

Optional T-RLY for gate control.

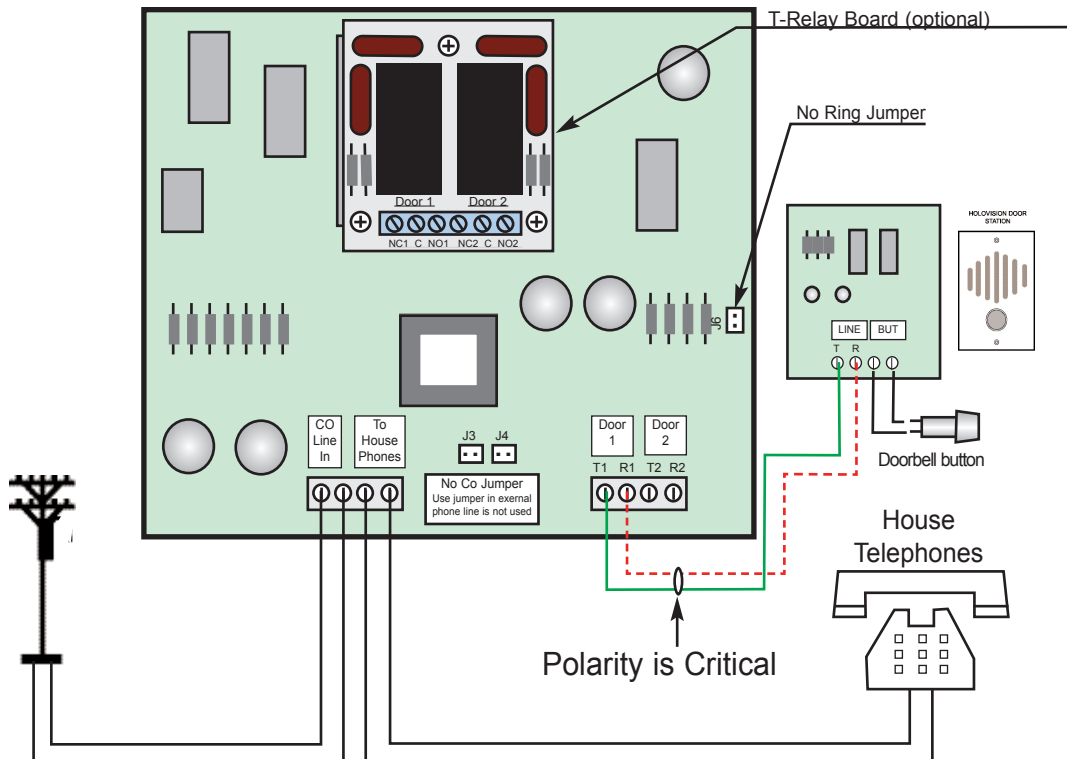

**NOTE:** Voltage from telephones is not necessary for the system to work. (See note "No CO operation" on page 2).  
The connection between the main board and the speaker board is **polarity sensitive**. Please note the connection shown above.

## INSTALLATION INSTRUCTIONS

501 E. Goetz Ave.  
Santa Ana, Ca 92707  
[www.eholovision.com](http://www.eholovision.com)

Ph. 714-434-6904  
Fax 800-362-0002

# HOLOVISION

# T-RLY Wiring

AC for Strike

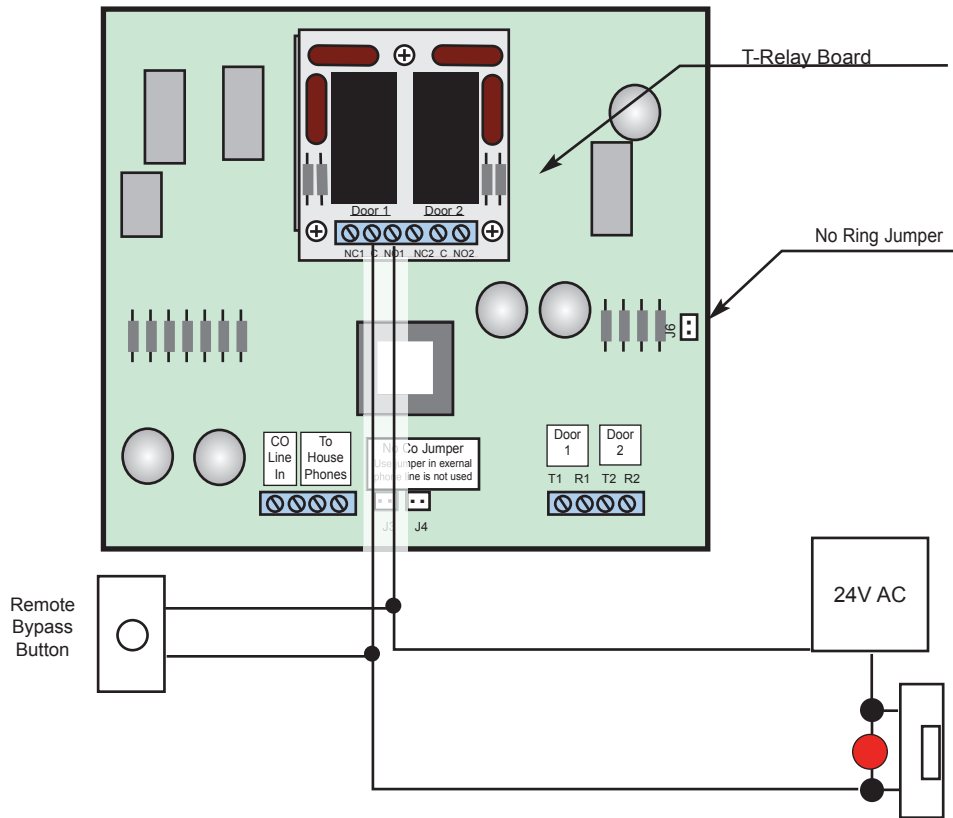

## Operation of TES2

### ANSWER THE CALL

When you hear the distinctive ring pattern selected above:

**within 10 seconds** - simply pick up any telephone to be connected to the door speaker which initiated the call.

**after 10 seconds** - pick up any telephone, flash, and you will be connected to door 1. To be connected to door 2, pick up telephone, flash, and hit "2"

### CALL WAITING

TES2 has built-in call waiting. If the house phone is in use when the door button is pushed, the caller will receive a call waiting tone. To answer the "door call" simply flash to answer the "door call" and flash again to return to the original call.

### SWITCH TO OTHER DOOR

Users can switch to the other door station at anytime by hitting "1" or "2" while connected to door 1 or door 2.

### INITIATE A CALL

To initiate the call from a phone in the house simply go off hook and flash for door 1 or go off hook and flash "2" for door two.

## Operation of T-RLY

**When communication to the gate has been established**, the T-RLY can be activated by pushing "6". The relay will be activated for 5 seconds. To increase the activation time, hold down the "6" key for the desired amount of time.

**When communication to the gate has NOT been established:**

Flash then press 1 for relay #1

Flash then press 2 for relay #2

# TES2 Telephone Entry System

---

## Basic Set-Up

Step	Action
1	Mount the main board near the telephone distribution center of the house and attach the telephone line from the service provider to the connection labeled " <b>LINE TO DEMARC</b> ".
2	Connect the house phone distribution system to the wire terminals labeled " <b>HOUSE PHONE</b> ".
3	Punch down " <b>ONE</b> " and " <b>TWO</b> " door stations. If only one door station is being used, it should be connected on the " <b>ONE</b> " punch down location. Note: The connection is polarity sensitive.

## Set "No Ring" Option (TES2 is shipped with this option **DISABLED**)

Step	Action
1	The " <b>NO RING</b> " option is to be used if external door chimes are being used in the house, and the phones should not ring when the door bell button is pushed. When the " <b>NO RING</b> " option is selected, the phones will not ring. When the homeowner hears the external door chime (not supplied by Holovision), and then picks up any telephone, they will be automatically connected to the door phone. No additional buttons need to be pushed. The door call will be available for 10 seconds after the button is pushed. After 10 seconds, follow the instructions shown for " <b>Basic Operation of TES2</b> ".
2	For " <b>NO RING</b> " option, install jumper pin (J6) on far right side of board. TES2 is shipped with this option disabled.
3	In order to connect door chimes and TES2, a <b>double pole button must be used</b> . The double pole button (Part number 9202) is available from holovision.

## Set "No CO Line" Option (TES2 is shipped with this option **DISABLED**)

Step	Action
1	For " <b>NO CO</b> " option is to be used if there is no CO (Central Office) line to the home. The No CO option would be used if the homeowners used cell phone only (no house phone line). In this case, several phones would be required throughout the house. These phones would be used only for answering door phone calls.
2	For " <b>NO CO</b> " option, install 2 jumper pins if (J3, J4) at the bottom of the board. TES2 is shipped with this option disabled.

## Connect Gate Strike Relay (OPTIONAL)

Step	Action
1	The relay board is equipped with screw terminals. This has connections for each relay in normally open (" <b>NO</b> ") and normally closed (" <b>NC</b> ") options.
2	Attach to either NO or NC connectors. If a second gate is being used, also connect it to NO or NC connectors.

## Door Ring Patterns

Door 1	3 groups of 3 rings (ring ring ring), (ring ring ring), (ring ring ring).
Door 2	3 groups of 2 rings (ring ring), (ring ring), (ring ring).

### Operation of TES2

#### ANSWER THE CALL

When you hear the distinctive ring pattern selected above:

**within 10 seconds** - simply pick up any telephone to be connected to the door speaker which initiated the call.

**after 10 seconds** - pick up any telephone, flash, and you will be connected to door 1. To be connected to door 2, pick up telephone, flash, and hit "2"

#### CALL WAITING

TES2 has built-in call waiting. If the house phone is in use when the door button is pushed, the caller will receive a call waiting tone. To answer the "door call" simply flash to answer the "door call" and flash again to return to the original call.

#### SWITCH TO OTHER DOOR

Users can switch to the other door station at anytime by hitting "1" or "2" while connected to door 1 or door 2.

#### INITIATE A CALL

To initiate the call from a phone in the house simply go off hook and flash for door 1 or go off hook and flash "2" for door two.

### Operation of T-RLY

If the TES2 Relay board is installed, the door latch/gate relay can be activated by pushing "6". The relay will be activated for 5 seconds. To increase the activation time, hold down the "6" key for the desired amount of time.

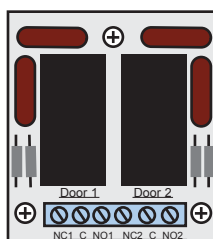



[www.eholovision.com](http://www.eholovision.com)

**501 E. Goetz Ave.  
Santa Ana, Ca 92707**

**Ph. 714-434-6904  
Fax 800-362-0002**