

# HOLOVISION

## Manual Type 6.0.0.5-RF

Viking W-1000 with  
C-1000B Controller

### For Models

- 413-VIK(W-1000) 414-VIK(W-1000)
- 420-VIK(W-1000) 421-VIK(W-1000)
- 423-VIK(W-1000)

Specifications	
<p><b>Communication</b></p> <p>Viking W-1000 Doorbox uses "half-duplex" communication, allowing for high speaker and microphone volume, without the possibility of feedback.</p>	<p><b>Access Control</b></p> <p>.C-1000B can open 2 doors</p>

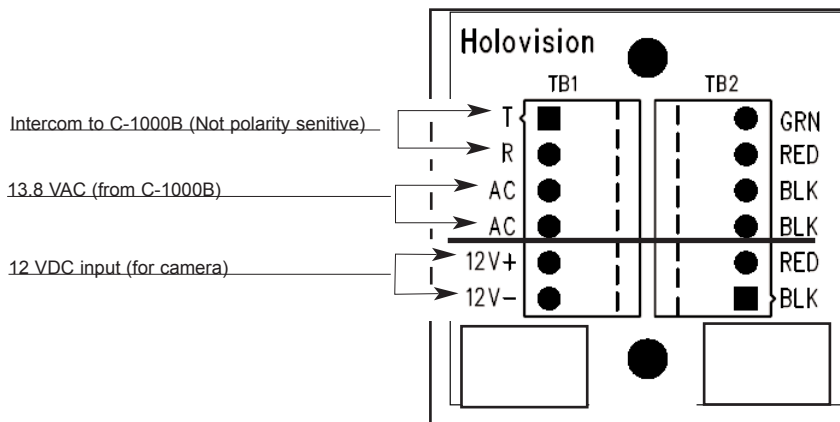

400 Series "Small" Junction Board

## INSTALLATION INSTRUCTIONS

501 E. Goetz Ave.  
Santa Ana, Ca 92707

[www.eholovision.com](http://www.eholovision.com)

Ph. 714-434-6904  
Fax 800-362-0002

# HOLOVISION

# Viking C-1000B Wiring Diagram

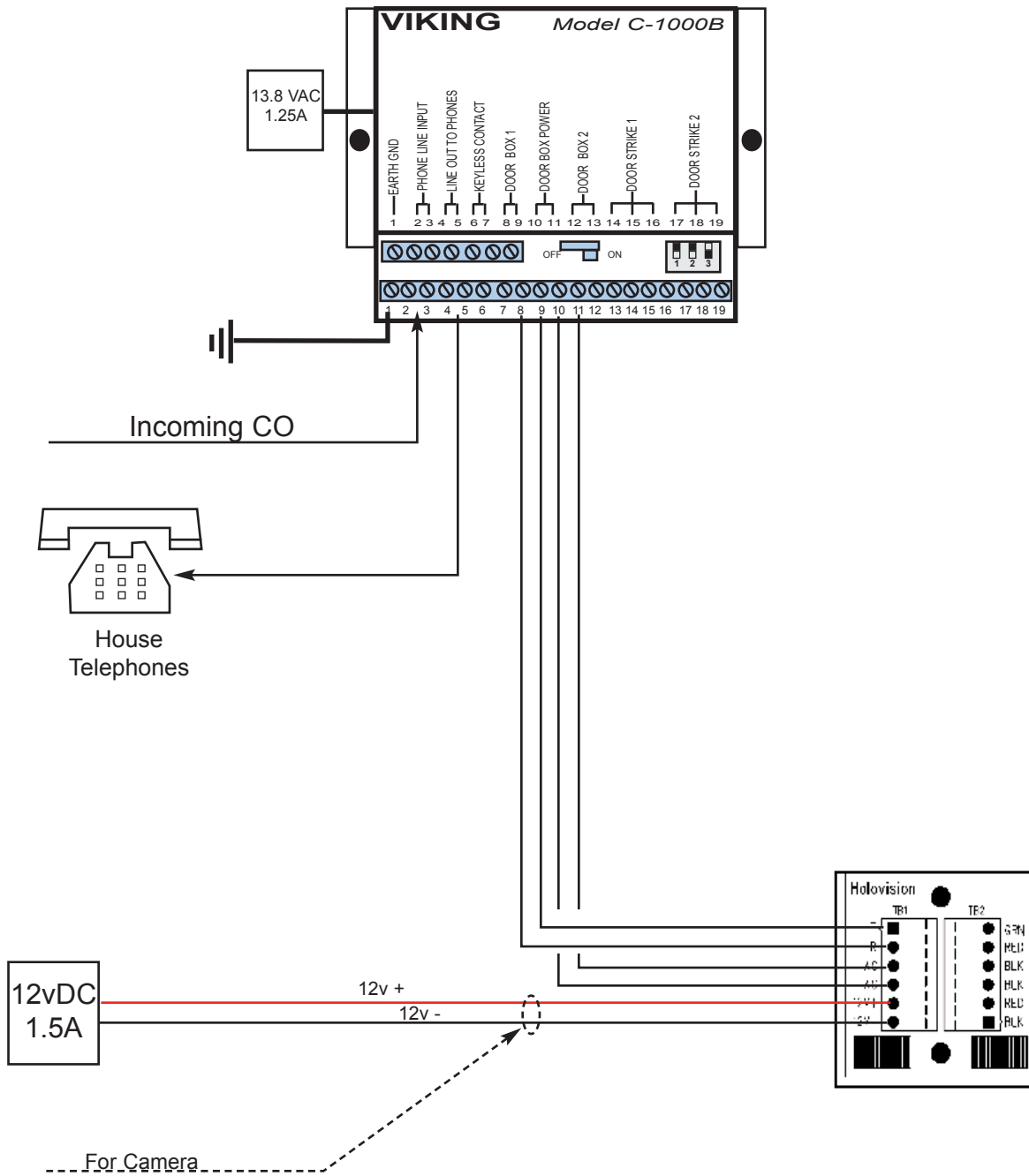

## W-1000 Adjustments and Programming

### Microphone Volume

In certain noisy locations (traffic or wind), the microphone volume may need to be decreased. A symptom of this is one-way talk path, in which the distant party cannot be heard over the speaker. A "MIC VOL" adjustment is provided on the doorphone for increasing or decreasing the microphone volume.

### Speaker Volume

The "SPKR VOL" pot can be adjusted to increase or decrease the speaker volume to the desired level.

### Maximum Number of Rings

The maximum number of rings can be adjusted using the DIP switches.

Sw 1	Sw 2	Max Rings
OFF	OFF	2
ON	OFF	3
OFF	ON	10
ON	ON	30

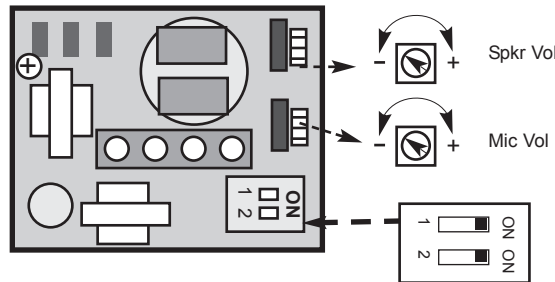

## C-1000B Door Controller Programming

The C-1000 controller is factory set to work right out of the box. If customization of the default settings is required, see the steps listed below. Refer to the C-1000 manual for additional options

Step	Action
1	Disconnect the PHONE LINE INPUT.
2	Slide the TALK BATTERY switch to the ON position.
3	Move DIP SWITCH 2 from OFF to ON.
4	Connect a phone to terminals 4 & 5 - LINE OUT TO PHONES.
5	Pick up the phone (you will hear a double beep - indicating that you have accessed the PROGRAMMING MODE).
6	You can now Touch Tone program the features listed below. SEE HOLOVISION PROGRAMMING NOTES.
7	When Finished, hang up and move DIP SWITCH 2 to the OFF position
8	Slide the TALK BATTERY switch back to the OFF position
9	Reconnect line to PHONE LINE OUT

## HOLOVISION's Programing Notes

**Doorstrike Activation Time** - Generally the default setting of 1/2 sec is fine. The momentary contact can open a motorized gate, or activate the relay on the "S-12" keypad. For other keypad types this will be changed.

**Doorbell Mode (\*1)**- phones will not ring when doorbell is pushed. This is useful when conventional door chimes are desired. In order to use this feature, the Auxiliary Contacts must be programmed. (see above)

**Custom Ring Mode (\*2)**- Distinguishes doorbox ring from CO ring when connected to KSU.

**CCTV Video Control Mode (\*8)**- The C-1000B can switch 2 CCTV cameras, displaying the camera at the doorbox which initiates the call. This mode cannot be used when the "Auxiliary Contacts" are being used.

**Disable Special Modes (\*0)** - Use this command to disable (clear) all special modes programmed.

REFER TO C-1000B MANUAL FOR MORE INFORMATION ON THESE, AND OTHER MODES OF OPERATION.

## Return to normal use mode

Step	Action
1	Slide the TALK BATTERY switch to the OFF position.
2	Move DIP SWITCH 2 from ON to OFF.
3	Re-connect the PHONE LINE INPUT and LINE OUT TO PHONES.

## OPERATION OF C-1000B

### ANSWER A CALL FROM DOORBOX

When the phones ring, pick up a phone to be connected to the visitor. When the C-1000B controller is used, you will hear a beep tone when the phone is answered - one beep for doorbox 1, and 2 beeps for doorbox 2.

### PLACING CO LINE CALLS ON HOLD (CALL WAITING)

If a phone call is in progress, and a door box is activated, a single or double "call waiting" tone will be heard. To place the call in progress on hold and speak to the visitor, push #. When you want to return to the original phone call, push #.

### ACTIVATING A DOORSTRIKE OR OPENING A GATE

To open the gate, you must first be connected to the doorbox. Push \*\*. You will then hear a confirmation tone, and the relay will be activated for the programmed time. If a call was already in progress, pressing \*\* will open the gate, and return the system to the original phone call.

### LATCH / UNLATCH A GATE

To use this feature, you must first be connected to the doorbox.

Latch relay 1 or 2 \* 1

Unlatch relay 1 or 2 \* 0