



Manual Type 6.4.0.3-RF
Viking E-10 Intercom & C-2000B Controller
with Essex Wiegand Keypad

For Models _____

400-W-VIK	401-W-VIK
403-W-VIK	404-W-VIK
410-W-VIK	411-W-VIK

Specifications	
<p>Communication</p> <p>Viking E-10 Doorbox uses “half-duplex” communication, allowing for high speaker and microphone volume, without the possibility of feedback.</p>	<p>Access Control</p> <p>Essex KPT-26TI 26 bit Wiegand Keypad</p>

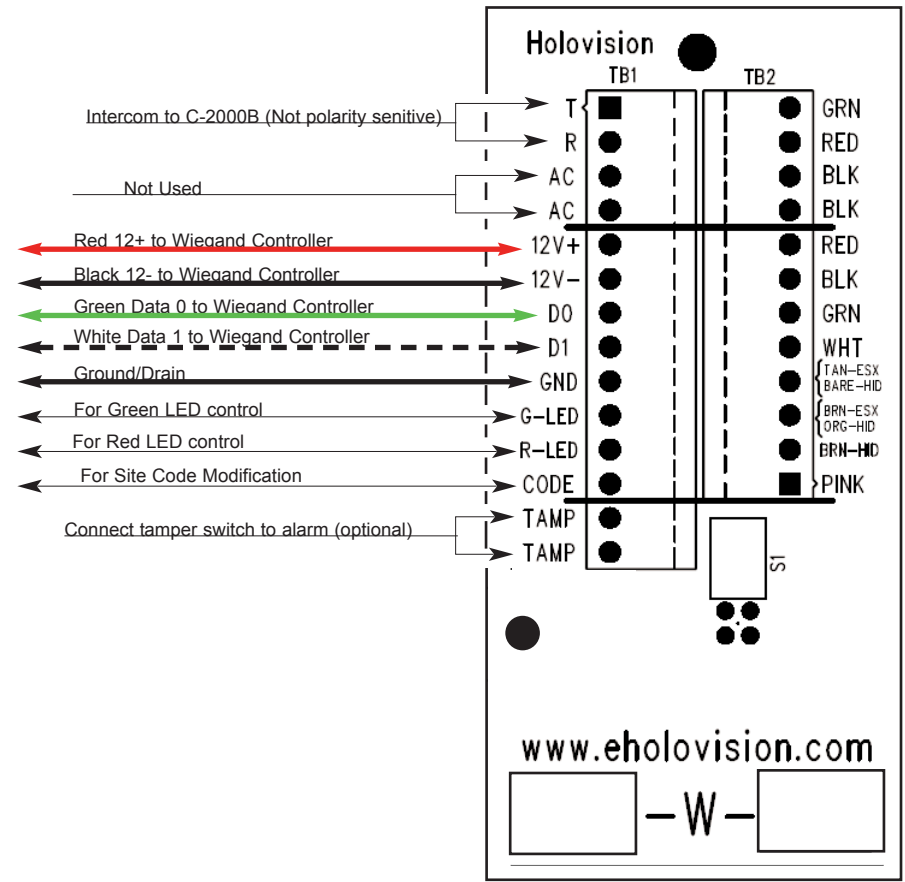

400 Series “W” Junction Board

INSTALLATION
INSTRUCTIONS

501 E. Goetz Ave.
 Santa Ana, Ca 92707

www.eholovision.com

Ph. 714-434-6904
 Fax 800-362-0002

HOLOVISION

Essex Keypad and E-10/C-2000B wiring

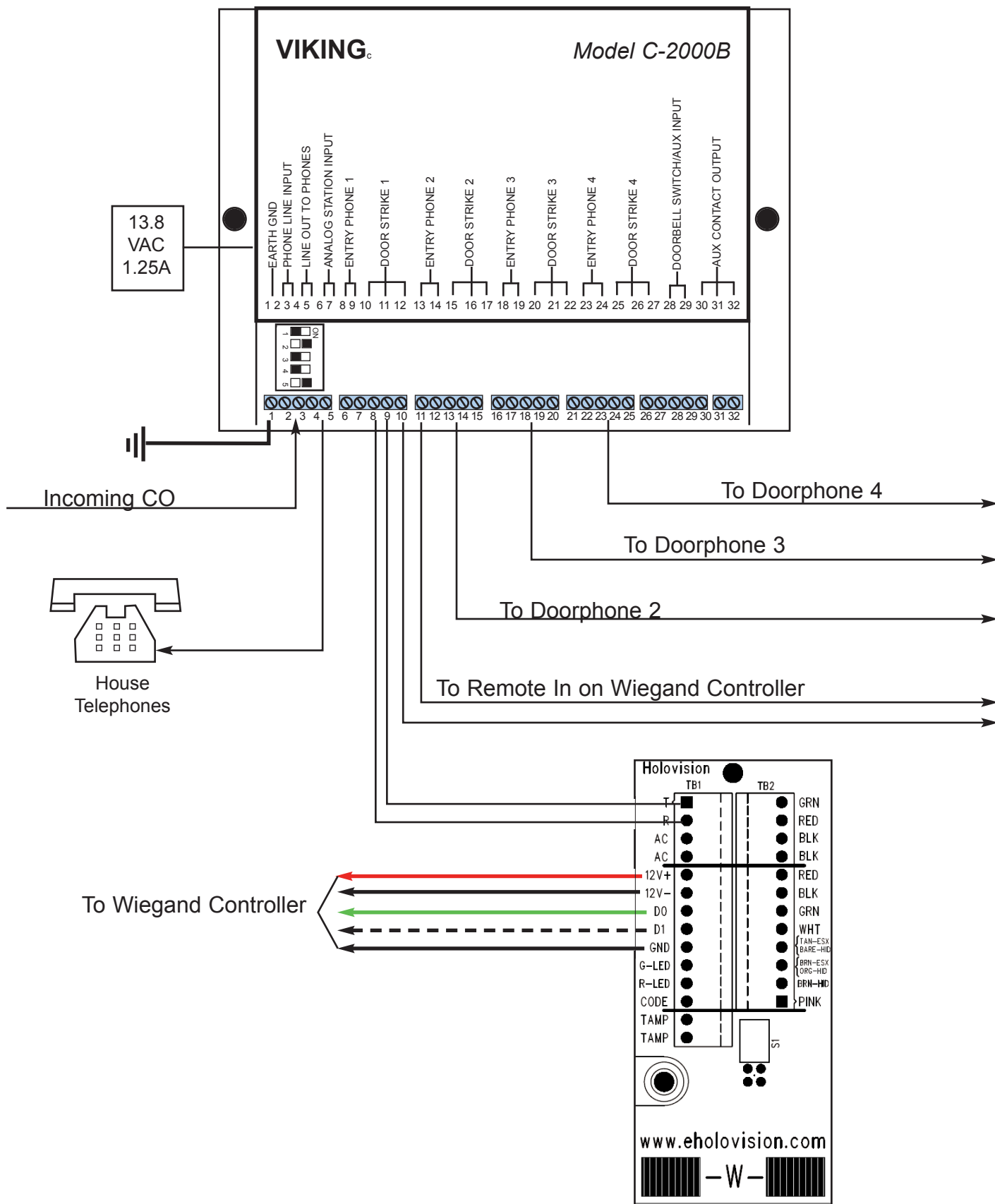

Doorphone Programming

Instructions for E-10 Doorphones

Microphone Volume

In certain noisy locations (traffic or wind), the microphone volume may need to be decreased. A symptom of this is one-way talk path, in which the distant party cannot be heard over the speaker. A "MIC VOL" adjustment is provided on the doorphone for increasing or decreasing the microphone volume.

Speaker Volume

The "SPKR VOL" pot can be adjusted to increase or decrease the speaker volume to the desired level.

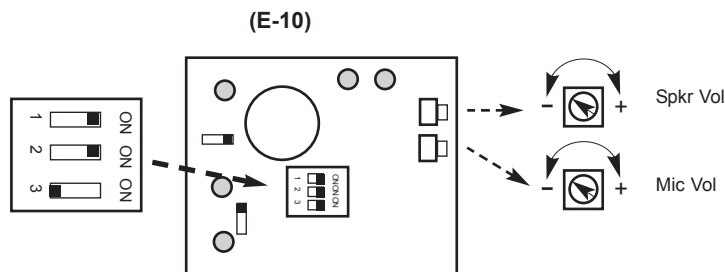

Dip Switch Settings

DIP Switch	Position	Description
1	ON	Auto Answer - Doorphone answers when incoming call is detected.
2	ON	Call Timer - See E-10 manual for a description of this feature. Recommended setting is "ON". This is the factory default.
3	OFF	Programming Mode - E-10 is factory pre-set, and normally does not need re-programming. Refer to E-10 manual (Viking document which is included) for details

Holovision recommends the default settings on the dip switches. See the E-10 manual for more information.

Instructions for C-2000B Controller

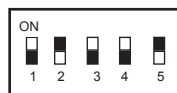

Dip Switch Settings C-2000B

DIP Switch	Position	Description
1	OFF	Auxiliary Contact Mode
1	ON	Doorbell Mode- Factory Default
2	OFF	Normal Operation Mode- Factory Default
2	ON	Security Code Bypass Mode
3	OFF	Entry Phone automatic disconnect (CPC) disabled
3	ON	Entry Phone automatic disconnect (CPC) enabled- Factory Default
4	OFF	Entry Phone busy signal disabled
4	ON	Entry Phone busy signal enabled- Factory Default
5	OFF	Single Line Ring Through Mode- Factory Default
5	ON	Analog Station Dial Through Mode

Programming the Viking C-2000B

Access Programming Mode (Local Access)

STEP	ACTION
1	Move DIP switch 2 from OFF to ON position.
2	Come off-hook with any house phone connected to terminals 4 & 5 LINE OUT TO PHONES .
3	Double beep indicates accessing the programming mode.
4	You can now program the C-2000A. The features covered in this manual are Maximum Doorphone Ring Count and Door Strike Activation Time . For information on programming other features see the Viking C-2000 manual.
5	Move DIP switch 2 back to the OFF position.

Maximum Doorphone Ring Count - Factory Default is 5 Rings

STEP	ACTION
1	Follow steps 1-3 from " Access Programming Mode " (above).
2	At "double beep" enter desired number of rings, followed by #61. Example: For 7 rings, enter "07#61".
3	Hang up the phone.

Program Gate Strike Relays - Factory Default is 0.5 Seconds

STEP	ACTION
1	Follow steps 1-3 from " Access Programming Mode " (above).
2	At "double beep" enter desired number of rings, followed by: #19 for Gate 1, #29 for Gate 2, #39 for Gate 3, #49 for Gate 4 Examples: Set Gate 1 for 8 seconds (08#19); Set Gate 3 for 15 seconds (15#39)
3	Hang up the phone.

Viking Operation

Operation Instructions for C-2000B Controller

ANSWER A CALL FROM DOORBOX

When the phones ring, pick up a phone to be connected to the visitor.

PLACING CO LINE CALLS ON HOLD (CALL WAITING)

If a phone call is in progress, and a doorbox is activated, one to four beeps will be heard (indicating which doorphone is calling). To place the call in progress on hold and speak to the visitor, push #. When you want to return to the original phone call, push #.

ACTIVATING A DOORSTRIKE OR OPENING A GATE

When a call is in progress, press ** to open the gate and return to the original call. If you do not want to open the gate, press # to return to the original call.

Set Keypad Illumination to On All of the Time

Step	Action
1	Cut Gray jumper wire on back of keypad.