



Manual Type 6.5.0.1-RF
 Panasonic Compatible
 with Essex "ASCII" Keypad

For Models

400-A-PAN	401-A-PAN
403-A-PAN	404-A-PAN
410-A-PAN	411-A-PAN

Specifications	
<p>Communication</p> <p>For use with all Panasonic KSUs with door phone card. This unit is a replacement for the Panasonic KXT-30865 door phone.</p>	<p>Access Control</p> <p>Essex K1-261 Keypad field configurable to ASCII, Wiegand and others.</p>

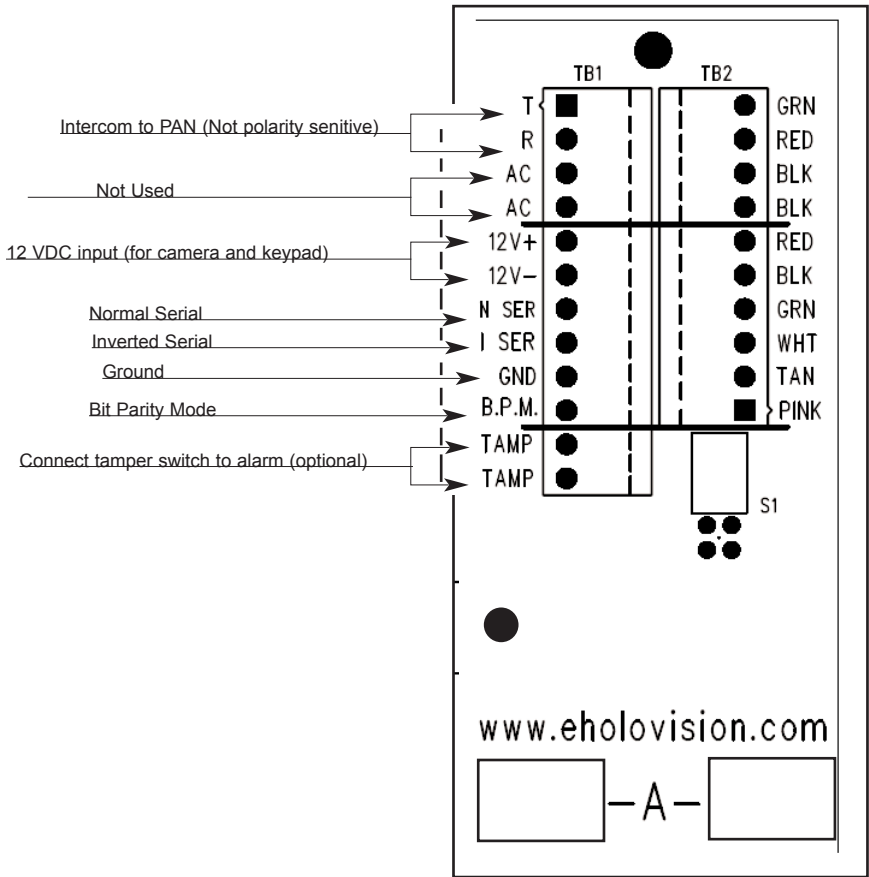

400 Series "A" Junction Board

**INSTALLATION
 INSTRUCTIONS**

501 E. Goetz Ave.
 Santa Ana, Ca 92707

www.eholovision.com

Ph. 714-434-6904
 Fax 800-362-0002

HOLOVISION

ASCII Connection to Crestron or HAI 400

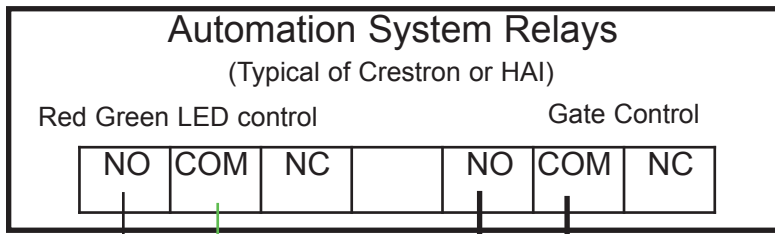

The red LED is normally on all of the time. When a valid code is entered, the relay controlling the LEDs would close, and the green light would go on (momentarily). Note, this relay must be programmed in Crestron or HAI in order for this to take place.

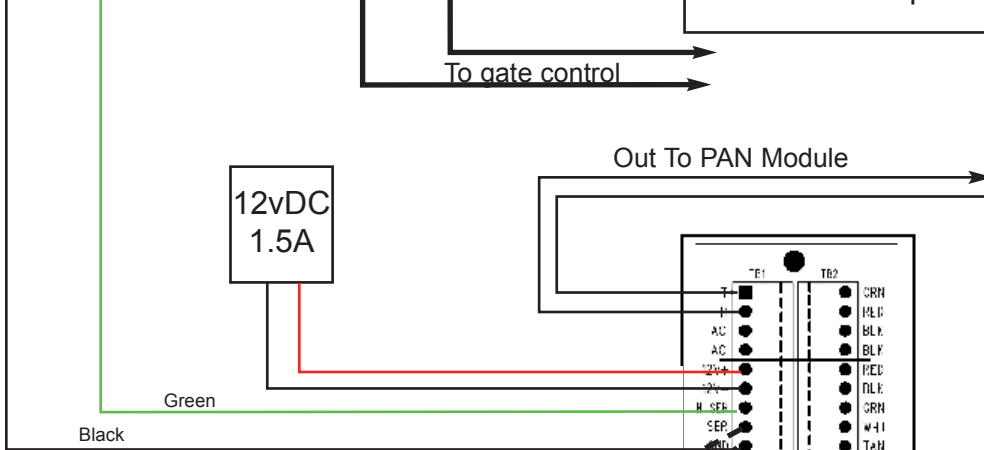

K1-261
ASCII Keypad

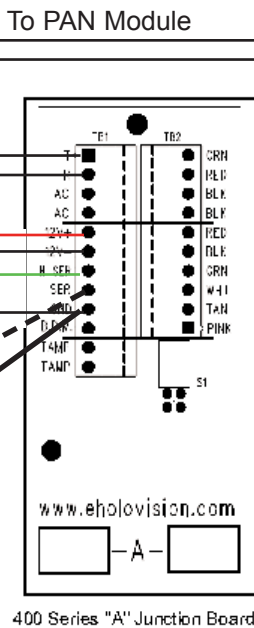

To Automation System
(see details below)

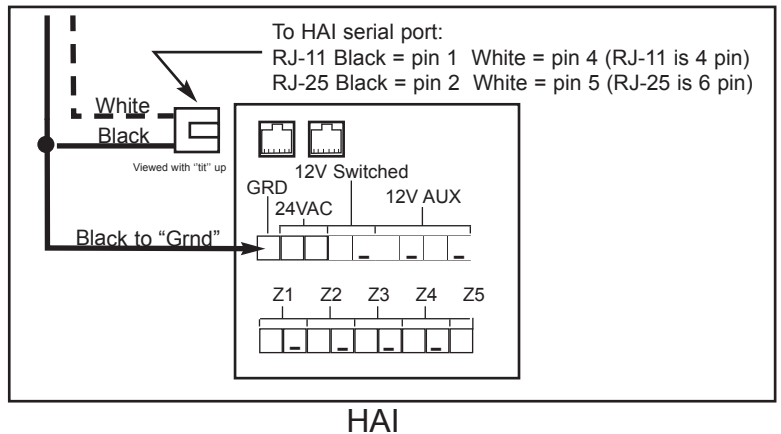
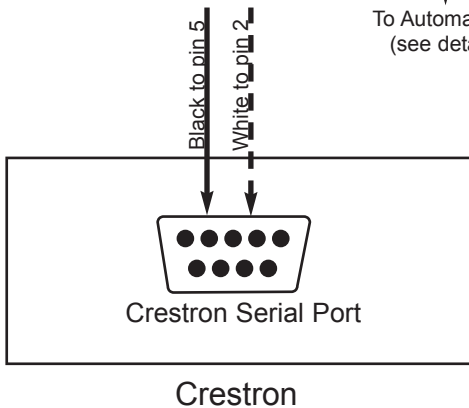

PAN Wiring Diagram

